

INSTALLATION MANUAL



ELECTRIC DUCT HEATER – modulating and on/off

TABLE OF CONTENTS

Product description	3
Dimensioned sketch	4
Installation	5
Installation instructions - modulating (ESM).....	5
Installation instructions - on/off (EKA).....	5
Installation position	5
Using the electric heater as a preheater/reheater	6
Optima controller with on/off electric heater.....	6
Optima controller with modulating electric heater	6
Operating and maintenance instructions	7
Electrical diagrams - modulating heater	8
Electrical diagrams - on/off heater	9

PRODUCT DESCRIPTION

This duct heater can be used in ventilation systems where there is a need for additional heating in the form of pre-heating or reheating.

The duct heater is available with duct connections in Ø125, Ø160, Ø200 or Ø250 mm dimensions. The heater is highly flexible, as it can be adjusted between:

- 300/600/900 W for heaters with a Ø125 mm connection.
- 300/600/900//1,200/1,500/1,800 W for heaters with a Ø160, Ø200 or Ø250 mm connection.

The housing and connection box are made of aluzinc-coated steel, which is resistant to high temperatures, and have rubber lips for duct connection. The heater has protection class IP44.

The duct heater is fitted with a safety thermostat that automatically switches off the power supply if the temperature exceeds 50°C. If the temperature drops, the heater is automatically reactivated.

For additional safety, there is a built-in thermal cut-out that trips if the temperature exceeds 100°C. Reactivation must be performed manually.

The modulating duct heater is designed with an electrical ESKM solid-state relay that is controlled by the PWM's on/off signal. The working range for ESKM modules is 6 - 24 VDC.

The duct heater is fitted with heating elements made of AISI 304 stainless steel.

To prevent the heating elements overheating, a minimum air velocity of 1 m/s through the duct is recommended.

DIMENSIONED SKETCH

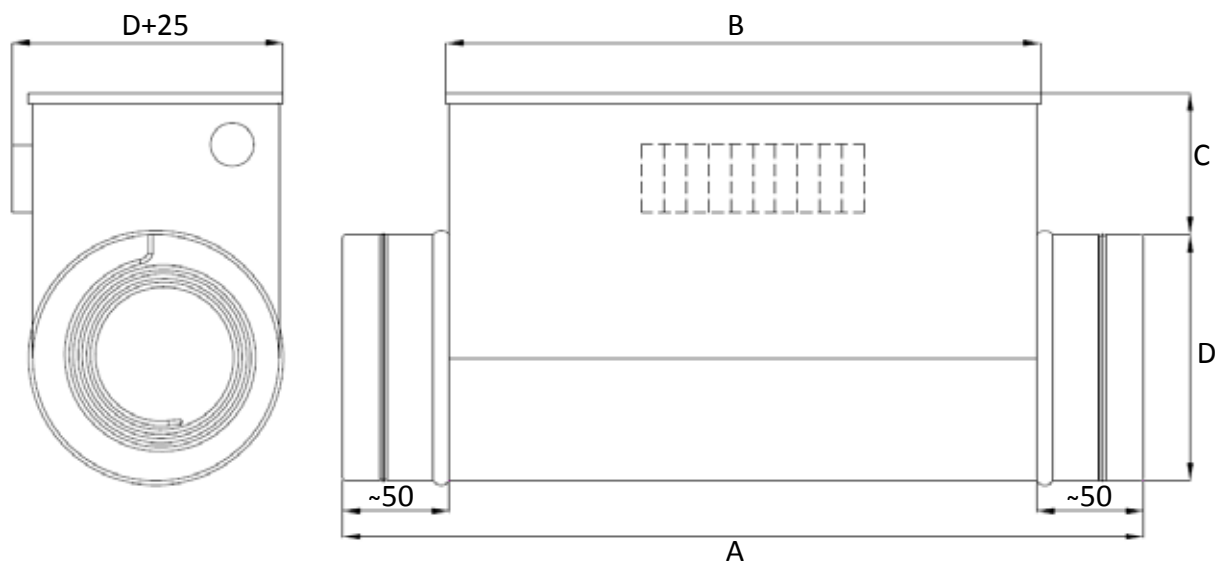

Dimensions

Duct heater	A (mm)	B (mm)	C (mm)	D (mm)
EKA ESKM 125	370	276	71	125
EKA ESKM 160	370	276	71	160
EKA ESKM 200	370	276	71	200
EKA ESKM 250	370	276	71	250

Min. airflows (m³/h)

Duct heater	Diameter	Min. airflow (m ³ /h)	Power supply (V AC/50 Hz)	Power (kW)
EKA ESKM 125	125	45	1-230	0.3...0.9
EKA ESKM 160	160	75	1-230	0.3...1.8
EKA ESKM 200	200	115	1-230	0.3...1.8
EKA ESKM 250	250	180	1-230	0.3...1.8

INSTALLATION

Installation instructions - modulating (ESKM)

Installation must be carried out with an automatic circuit breaker/fuse with a min. contact distance of 3 mm per pole for the heater. Permanent installation must always be carried out by an authorised electrician and in accordance with local wiring regulations. Installation must be carried out in such a way that the requirements for minimum air velocity are met.

These installation instructions should be read in conjunction with the Genvex Installation Manual and the operating manual for the ventilation product, which provides connections for the Optima circuit board and commissioning instructions.

1. Switch off the power supply to the socket with an automatic circuit breaker/fuse.
2. Connect the control cable (12 VDC PWM) to the Genvex Optima controller.
3. Connect the heater's supply cable to the mains socket (230 V).
4. Switch on the power supply to the socket with an automatic circuit breaker.

The duct heater is pre-installed with maximum heating power. Disconnect the jumpers for lower power requirements in accordance with the wiring diagrams. Disconnected jumpers must be removed safely.

Installation instructions - on/off (EKA)

The electric heater can be connected to output H3 on the Optima circuit board. Permanent installation must always be carried out by an authorised electrician and in accordance with local wiring regulations. Installation must be carried out in such a way that the requirements for minimum air velocity are met.

These installation instructions should be read in conjunction with the Genvex Installation Manual and the operating guideline for the ventilation product, which provides connections for the Optima circuit board and commissioning instructions.

1. Switch off the power supply to the Optima controller.
2. Connect the heater's supply cable to output H3 on the Optima controller (230 V).
3. Switch on the power supply to the Optima control board.

The duct heater is pre-installed with maximum heating power. Disconnect the jumpers for lower power requirements in accordance with the wiring diagrams. Disconnected jumpers must be removed safely.

Installation position

The duct heater can be installed in any position (see the illustration below) except with electrical connections in the downward direction.



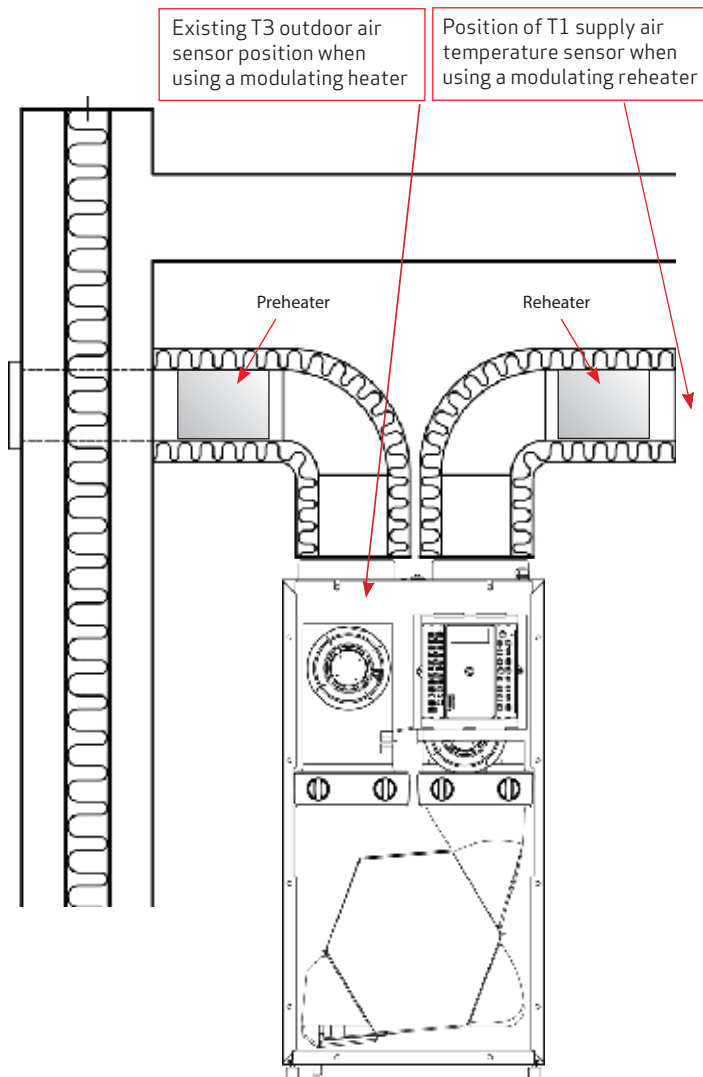

Using the electric heater as a preheater/reheater

The high heat recovery rate of a Genvex ventilation system may result in icebuilding in the heat exchanger on the discharge air side and can lead to the requirement to install an electric preheater. The preheater is installed in the fresh air intake before the ventilation system (see the illustration on the left).

The output from the heater can be changed from 300 W to 900 W (for Ø125) or from 300 W to 1800 W (for Ø160 and up). It is especially important to adjust the heat output for the on/off heater to avoid wasting energy.

Adjusting the output of the modulating heater is also recommended to ensure a more even regulation of the heater's performance.

It is recommended to disable the Optima controller's software defrost feature when using an electric heater at the same time.

Optima controller with on/off electric heater

Connect the electric heater to terminal H3 (230 V) and earth.

On/off electric heater used as a preheater

The existing fresh air sensor (T3) installed in the unit is removed from terminal L3 and replaced with a new, longer equivalent sensor (accessory) that is placed in the fresh air duct before the heater (see the illustration).

On/off electric heater used as a reheater

The existing supply air sensor (T1) installed in the unit is removed from terminal L3 and replaced with a new, longer equivalent sensor (accessory) that is placed in the supply air duct after the heater (see the illustration on the left).

Please note that there may be a risk of increased electricity consumption when using an on/off electric heater as a reheater if the setting and adjustment are not carried out correctly.

Optima controller with modulating electric heater

Connect the electric heater's PWM wire to the "open collector" output L10 on the Optima circuit board. The L10 will modulate the electric heater with a 12 V output signal to deliver just the right amount of energy to maintain the temperature set in the Optima controller.

The modulating electric heater requires a separate 230 V supply.

The modulating electric heater used as a preheater does not require repositioning of the fresh air sensor T3, as the sensor built into the ventilation unit can be used.

The modulating electric heater used as a reheater: The existing supply air sensor (T1) installed in the unit is removed from terminal L3 and replaced with a new, longer equivalent sensor (accessory) that is placed in the supply air duct after the heater (see the illustration).

IMPORTANT

- Avoid opening the top cover when the power supply is switched on.
- When not in use, store the electric duct heater in a dry place: relative humidity < 60%, temperature > 15°C.
- Parts of the duct heater can become hot during use.
- Avoid placing the duct heater under or close to a bathtub, shower cubicle, sink or other areas that could cause water to enter the electric heater.
- For stationary duct heaters, such as those used in a bathroom, the heater must be installed in such a way that the switch and other parts for adjustment cannot be reached from the bathtub or shower cubicle.
- The duct heater must be positioned so that there is no risk of ignition of flammable materials.
- Duct heaters may only be used to heat clean (fresh) air.
- The heater must be insulated against external condensation if it is used as a preheater and placed in a heated room in the home. Take care to allow the heater to be serviced after insulation.

Operating and maintenance instructions

It is recommended to check the following 12 months after installation:

- Terminal connections must be tightened with a maximum factor of 2 Nm.
- Insulation resistance of the heating element: Connect the Megger to an earth screw and on the phases. If the measured value is below 20 Mohm, check each individual heating element. The insulation resistance must be min. 50 Mohm at 1,000 V.

Heating elements MUST only be replaced by the manufacturer.

NOTE

If the heating elements do not heat up, disconnect the power supply and rectify the fault. Afterwards, press the reset button to activate the overheating protection located on the top cover.

ELECTRICAL DIAGRAMS - MODULATING HEATER

EKA ESKM 125-0.9kW-1f_STP

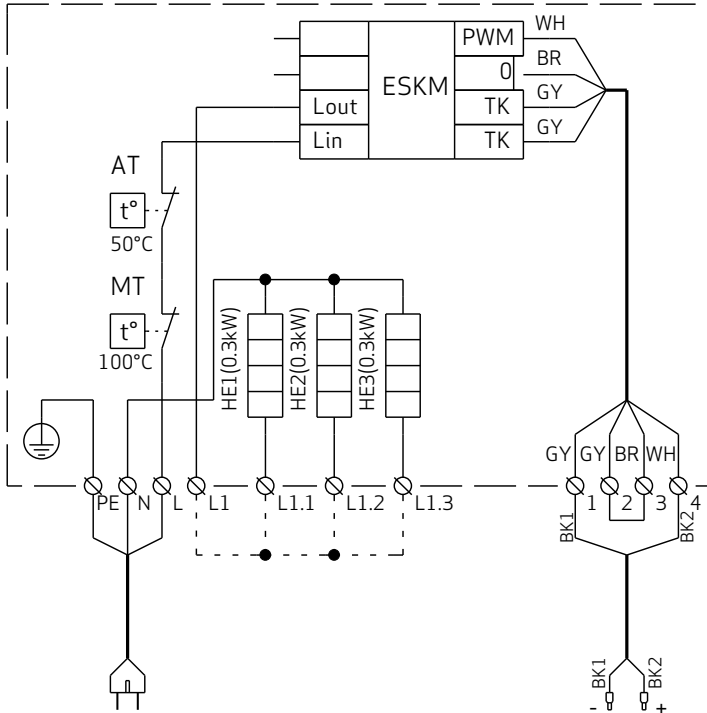

AT - Automatic reset thermo switch
MT - Manual reset thermo switch
HE1...HE3 - Heating elements

PWM
(6...24VDC)

Power output wiring

	300W	600W	900W
L1	●	●	●
L1.1		●	●
L1.2	●	●	●
L1.3			●

EKA ESKM(160/200/250)-1.8kW-1f_STP

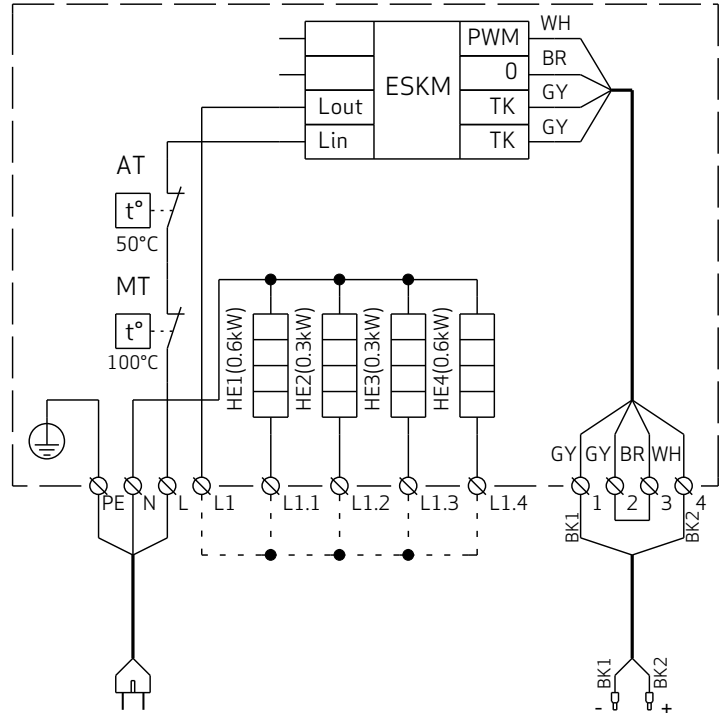

AT - Automatic reset thermo switch
MT - Manual reset thermo switch
HE1...HE4 - Heating elements

PWM
(6...24VDC)

Power output wiring

	300W	600W	900W	1200W	1500W	1800W
L1	●	●	●	●	●	●
L1.1		●	●	●	●	●
L1.2	●		●		●	●
L1.3						●
L1.4				●	●	●

Power (W)	300	600	900	1200	1500	1800
Current (A)	1.3	2.6	3.9	5.2	6.5	7.8
Resistance (Ohm)	179	90.9	59.5	45	36.1	30.1

ELECTRICAL DIAGRAMS - ON/OFF HEATER

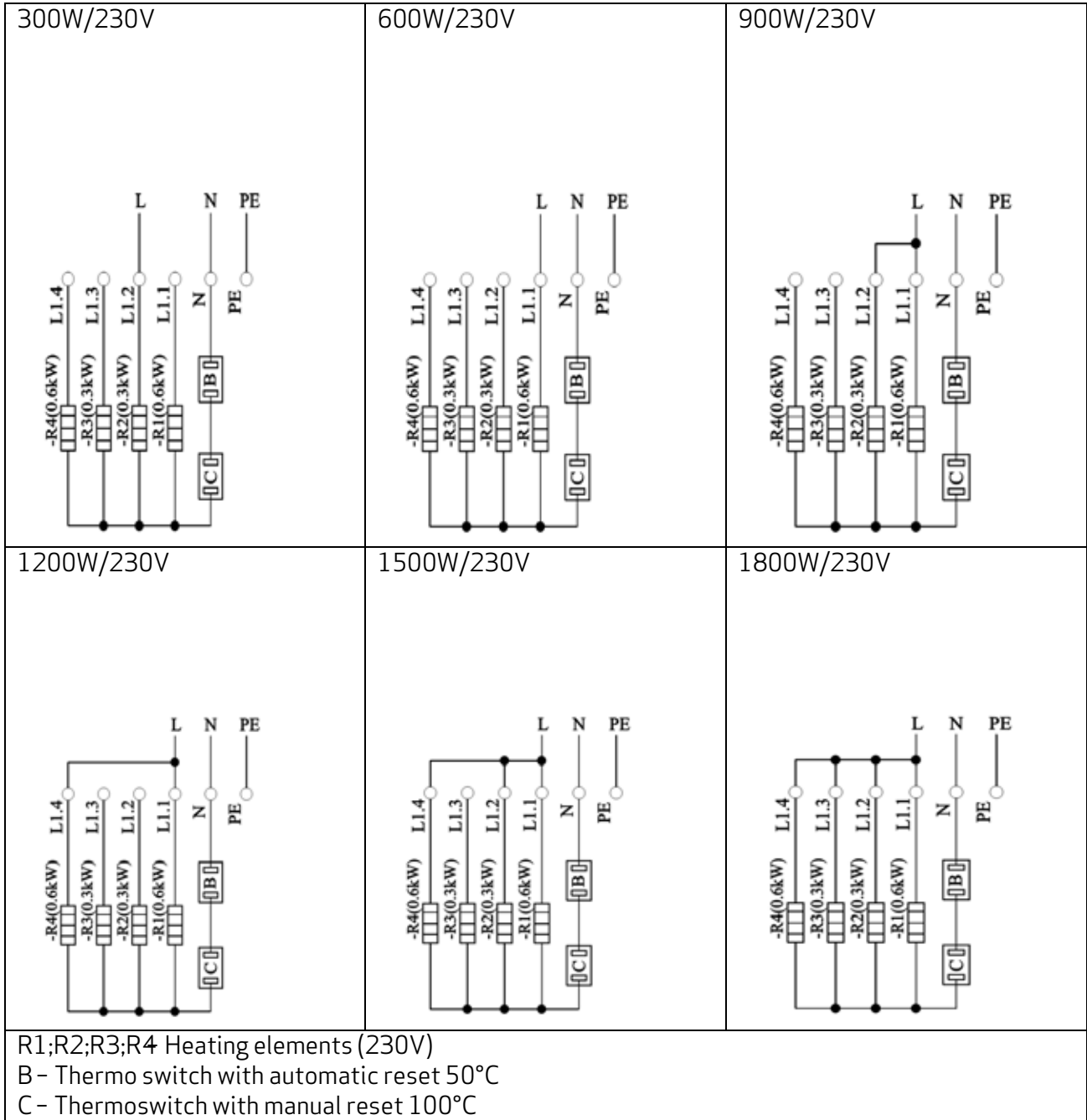

Power (W)	300	600	900	1200	1500	1800
Current (A)	1.3	2.6	3.9	5.2	6.6	7.9
Resistance (Ohm)	179	90.9	59.5	45	36.1	30.1

THE AIR WE BREATHE

All
Genvex
systems are
rated with
energy label

A

Genvex develops ventilation units that use as little energy as possible, whilst still being as efficient as possible. This is good for the environment – and will also save you money. Our units comply with all applicable standards and are easy to use, install and maintain. Last – but not least – all Genvex units have compact dimensions that makes them easy to install seamlessly in all types of homes – large or small.

Genvex is a part of the Swedish NIBE Group, which has specialised in providing environment-friendly energy solutions throughout the last 70 years. The NIBE group consists of more than 140 companies all over Europe.



Genvex – the original Danish ventilation system

Genvex is a true Danish original. We started producing ventilation systems in 1978 and are still the front runners when it comes to development and production of the most innovative and durable ventilation systems on the market.

Our units are installed in thousands of homes, providing clean, fresh air free from pollen, dust and harmful particles. They help lots of families with maintaining a healthy and comfortable indoor climate and prolong the longevity of the house itself. With very high heat recovery rates, a Genvex system lets you recover and reuse up to 95 % of the heat inside your home. As a result, our units provide a strong contribution to energy savings in both in family homes and in society as a whole.

Please visit www.genvex.com to see a list of our distributors