

INSTALLATION INSTRUCTIONS



COMBI BLUELINE

TABLE OF CONTENTS

Safety Information	3
About the Product	4
Transportation and Storage	4
Directions/Safety Instructions.....	4
Product Description.....	4
Combi Blueline Overview	6
Installation	7
Installation.....	7
Connecting to a Water Mains	7
Connecting to Condensate Drain.....	8
Duct connections.....	9
Ducting System.....	10
Insulation of Ducts in Heated Spaces.....	11
Electric Water Heater/Sensor/Anode/Thermostat.....	12
Electrical Installation	13
System Inspection and Fine-Tuning	13
Optimal Fine-Tuning of the System.....	14
Requirements to the Hot Water Circuit	14
Initial Operation of the Water Circuit	14
Cooling Circuit.....	14
Heat Exchanger Operation.....	15
Energy-Saving Tips.....	15
Fan Operation Tips.....	15
Rechecking.....	15
Electrical Diagrams	16
Flow Diagram	18
Hydraulic Connections	19
Modes of Operation	20
Spare Parts	22
Declaration Of Conformity	23
The Air We Breathe	24

SAFETY INFORMATION

This manual also describes installation and service work to be performed by a professional. This device can be used by children aged 8 and over and by people with reduced physical, sensory and mental capabilities or lack of experience and knowledge, as long as they are supervised or have been instructed in the safe use of the unit and understand the dangers involved.

Children must not play with the device. Children must not clean or maintain the appliance without supervision.

Subject to design changes.

Labelling

The CE mark represents Genvex's assurance that the product complies with all regulations laid down for the product in accordance with relevant EU directives.

The CE mark is mandatory for most products sold in the EU, irrespective of where they are made.

ABOUT THE PRODUCT

Transportation and Storage

It is recommended to store the unit in an upright position and without water. During transportation, the unit can be tilted up to 45 °C if it is done carefully and over short distances. The unit can be transported and stored within a temperature range of -20 to +70 °C.

If transporting the heat pump with a forklift truck, it should be placed on the provided base mount and lifted slowly. Due to its high centre of gravity, the unit must be secured to prevent it from toppling during transportation.

When using a sack trolley for transportation, it is important to secure the unit to prevent slipping and avoid using water pipe connections for transportation purposes. Additionally, care should be taken to ensure that the sack trolley does not cause damage to the cabinet and connectors.

During unloading, it is important to place the unit on a level surface to prevent damage.

Directions/Safety Instructions

- The unit's construction adheres to all EU regulations (refer to the CE certificate for more information).
- Precautions must be taken against fire during maintenance work that involves opening the coolant circuit, especially if the work involves fire-related tasks such as welding or soldering.
- Prior to commencing work on the unit, it is crucial to disconnect all electrical connections.
- When connecting the unit, it is important to comply with all relevant laws and regulations.
- The water used must be of potable grade, and if the water pressure is high, a pressure reduction valve must be installed.
- All connections related to potable water must be certified. Note: Only a certified contractor should perform any work.

Product Description

Use

The Combi Blueline is a combined ventilation unit and domestic water heat pump which can be used for:

- Air Heating
- Domestic hotwater;
- Ventilation with heat recovery;
- Air cooling both passively using the built in bypass and actively using the heatpump

Description

The Combi Blueline is a unit that comes ready to connect and consists of several important components, including the cabinet, tank, refrigerant, ventilation unit, heatpump as well as a control unit. The Combi is provided with a heat exchanger built in to the domestic hotwater cylinder with an area of 0.75 m², enabling connection to external heat sources such as a solar heating system. By using residual heat in the extracted air, the Combi Blueline heat pump can heat the supply air or produce domestic hot water.

Throughout the year, the Combi Blueline unit can provide a family's hot water needs by heating domestic water.

The tank has a built-in immersion heater, and sensors placed at the bottom and in the middle of the tank used for temperature regulation in the tank.

DHW capacity

The Combi Blueline unit has the capacity to heat 185 litres of domestic water to a temperature of 52°C within 8 hours, but this may vary depending on factors such as the temperature of the heat source, cold water and DHW tapping pattern. To handle peak loads, an integrated electric immersion heater with a 1 kW output is available. Compared to a directly heated tank, the Combi Blueline unit consumes only about 30% of the electric energy.

The control unit (Optima 314) activates the compressor as soon as hot water is used and the bottom of the tank cools down, and it runs until the sensors detect that the entire tank has reached the set temperature. The Combi Blueline unit is capable of satisfying the hot water needs of an entire family. In case of insufficient hot water production, the immersion heater can be manually activated via the control unit to produce double the amount of hot water. However, using the immersion heater consumes more energy than the compressor, so it should only be used during peak loads.

Heatpump process

The coolant circuit of the Combi Blueline is hermetically sealed and uses R134a coolant as an energy carrier. The heating module functions by removing heat from the air and transferring it to the coolant via the condenser. The coolant is compressed by the compressor and transported to the domestic water heater and/or the supply air duct. The compressor transfers energy into the coolant, which then heats either the water or the air that requires heating. The coolant then condenses and reverts to a fluid state.

Defrosting

When the temperature difference between the temperature prior to the cooling coil and the temperature of the cooling coil itself becomes too large, which occurs when there is ice formed on the cooling surface, the unit will begin to defrost. The supply air ventilator and the electric heating coils will disengage. The discharge air ventilator will continue to run together with the compressor, which will send hot gas directly into the evaporator until the ice melts and the cooling coil reaches a temperature of around 5 °C, depending on the temperature setpoint in the Optima314 controller. When the defrosting process has finished the supply air fan and the electric heating coil will re-engage balanced deicing mode where the supply air fans run simultaneously with the extract air fan is also possible but will increase the defrosting process.

Scope of Delivery

- Combined ventilation and heatpump unit with controls.
- Installations Instructions and Instructions for use

Accessories

- Temperature sensor for solar cells/central heater/geothermal pipes
- Electric preheater
- Electric or water-based reheater

Please refer to spare parts section of this manual.

COMBI BLUELINE OVERVIEW

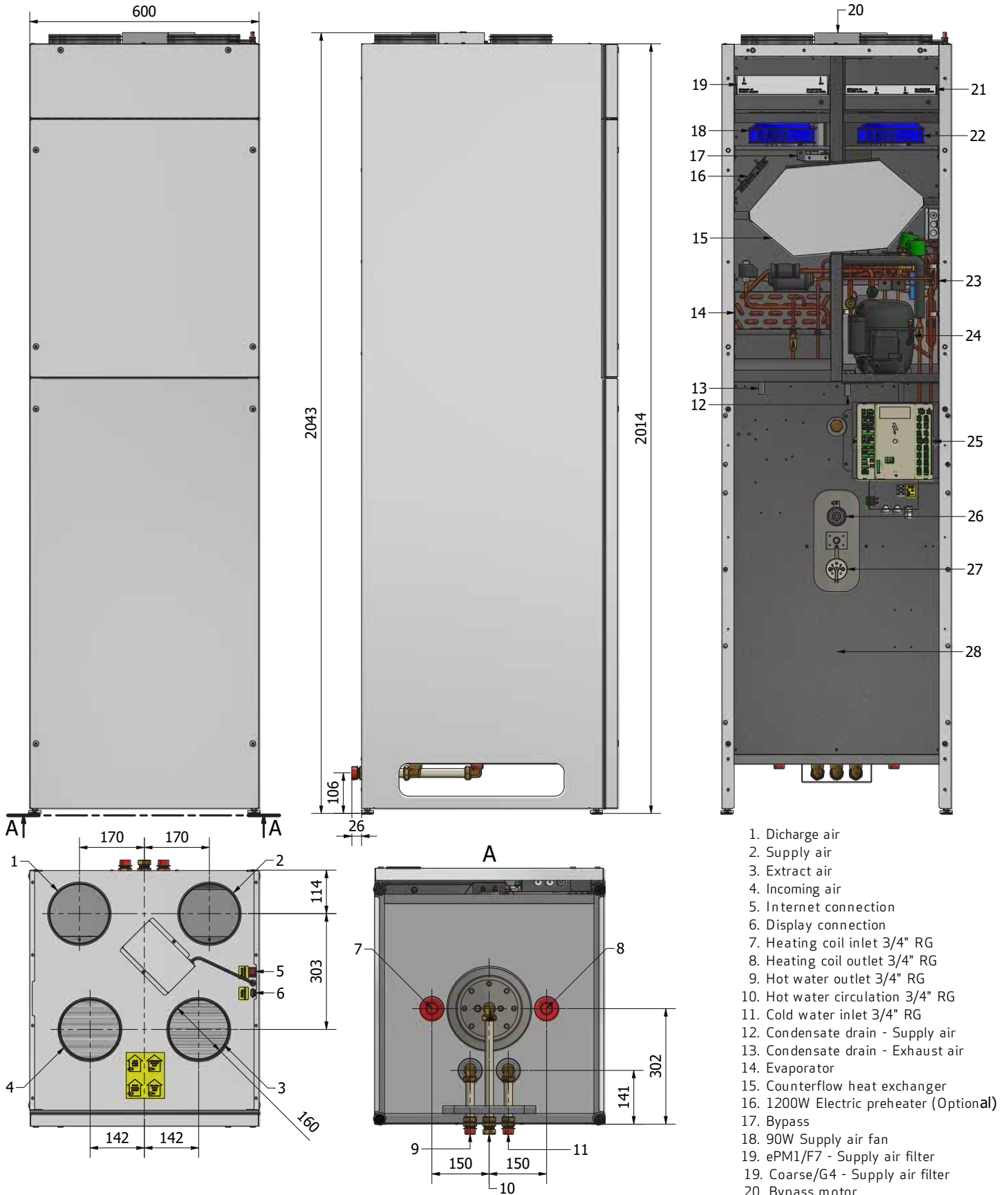

1. Discharge air
2. Supply air
3. Extract air
4. Incoming air
5. Internet connection
6. Display connection
7. Heating coil inlet 3/4" RG
8. Heating coil outlet 3/4" RG
9. Hot water outlet 3/4" RG
10. Hot water circulation 3/4" RG
11. Cold water inlet 3/4" RG
12. Condensate drain - Supply air
13. Condensate drain - Exhaust air
14. Evaporator
15. Counterflow heat exchanger
16. 1200W Electric preheater (Optional)
17. Bypass
18. 90W Supply air fan
19. ePM1/F7 - Supply air filter
20. Coarse/G4 - Supply air filter
21. Bypass motor
22. Coarse/G4 - Extract air filter
23. 90W Extract air fan
24. Condenser
25. Compressor
26. Optima 314 controller
27. 5/4" anode
28. 1 kW electric heating element
29. 185 L. tank

INSTALLATION

Installation

The Combi Blueline unit should only be installed in premises that are free from frost. The premises must meet certain prerequisites, including a room temperature between 8 and 35 °C for operation using room air, condensate drainage, no abnormal dust load in the air, and a solid foundation that can take the total weight of the Combi Blueline when full of water (400 kg). To ensure proper operation and allow for repairs and maintenance, it is recommended to keep a clearance of 0.6 m in front of the unit.

During installation, remove the packaging material, corner protectors, and transport mounts from the pallet. Lift the unit off the pallet and position it, then level it by turning the adjustable support legs.

When setting up the product careful planning is advised in relation to the position of any living room to avoid unsatisfactory noise or vibration, which may occur due to the fans and/or heat pump combined with unsuitable installation conditions. It is recommended that the system is not installed immediately adjacent to a bedroom, and that it be fastened to a heavy structure such as concrete. To prevent sound or vibration transmission, anti-vibration materials and soundproofing may be necessary in the installation room.

The air used in the Combi Blueline unit should not be polluted with aggressive substances like ammonia, sulphur, or chlorine, as these can damage the cooling system components.

Connecting to a Water Mains

During installation, to ensure that there is sufficient pressure and water where the water is drawn, take into consideration the pipe dimensions in relation to the existing water pressure and pressure loss.

The aspects of the installation that have to do with water must comply with the local water supply regulations. The water pipes to be used in the hotwater installation must be approved for drinking water. Take into consideration the corrosive properties of the materials used to avoid damage.

As with all pressurised containers, the tank of the unit must be fitted with an approved safety valve and an approved check valve on the supply side (always check the local requirements).

The inflow of fresh cold water and the outflow of hot water take place underneath the tank (3/4" RG connection). The maximum operating pressure is 10 bar, and the maximum operating temperature is 65 °C.

If necessary, the supply pipe must be fitted with a pressure reduction valve and possibly with a filter.



When fitting the piping in the dwelling, avoid contaminating the pipes. If required, flush the pipes with clean water before connecting the unit.



When fitting pipes, take care not to twist the pipe connections. Use a pipe wrench to apply counter pressure.



If recirculation is not used, make sure that the recirculation pipe connection is fastened securely.



Due to the efficient cooling capacity of the Combi Blueline unit, the supply air temperatures can reach temperatures below the dew point which in some cases may lead to condensate forming outside the supply air ducts. It is advised to insulate the supply air pipework against condensation and/or to maintain a suitable level of airflow that prevents the supply air temperature to drop below the dew point

Connecting to Condensate Drain

A significant amount of condensate will form due to the cooling of the air that passes through the heat exchanger. The condensate drain from the supply and the extract air side of the unit is fitted with hoses that can be looped to form a condensate watertrap. The end of the hose will have to be connected to a floor gully or a drainage system.

To ensure proper operation of the Combi unit, ensure that the two watertraps hold at least 100 mm watercolumn.

Ensure that the hose drops at least 1 % downward to the drain to ensure sufficient draining of condensate.

Depending on air humidity, the amount of condensate formed can reach 1 l/h.

100 mm

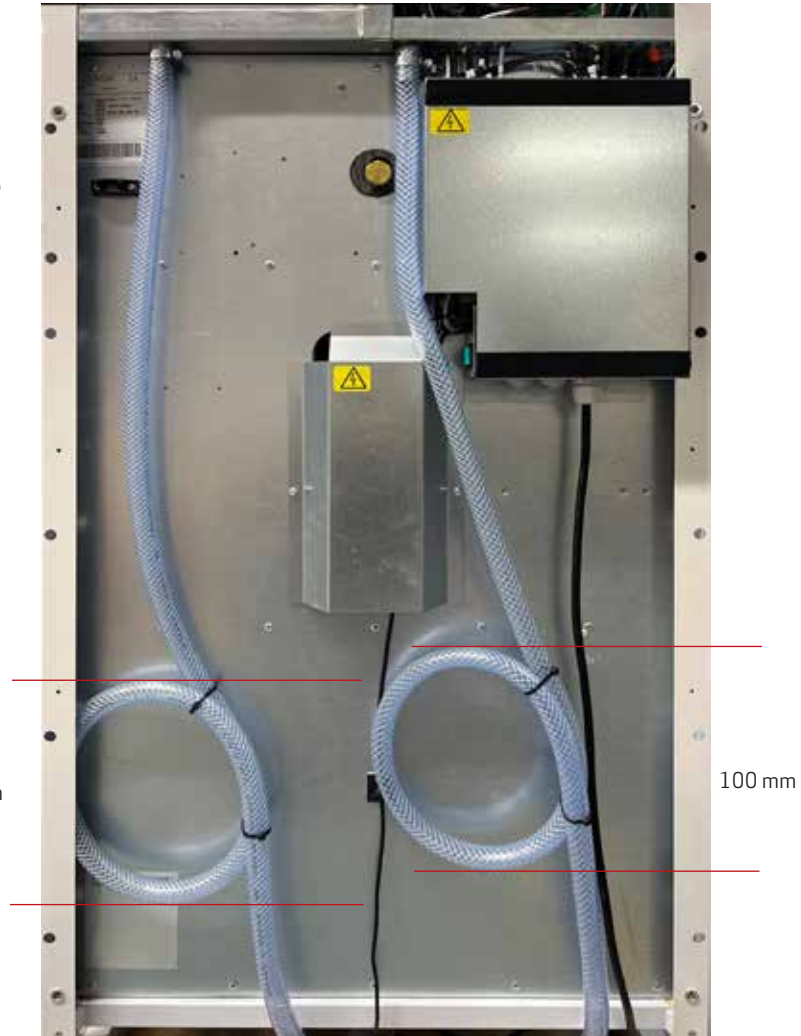

100 mm

Duct connections

On the top of the unit a sticker indicating the connections of the Combi has been fitted.

Supply Air

The ducting system leading from the unit to the rooms of the house.

Extract Air

The ducting system leading from the house wet rooms to the unit.

Incoming Air

The ducting system leading from the fresh-air roof cowl/ fresh-air grating outdoors to the unit.

Discharge Air

The ducting system leading from the discharge air roof cowl/discharge air grating to the unit.

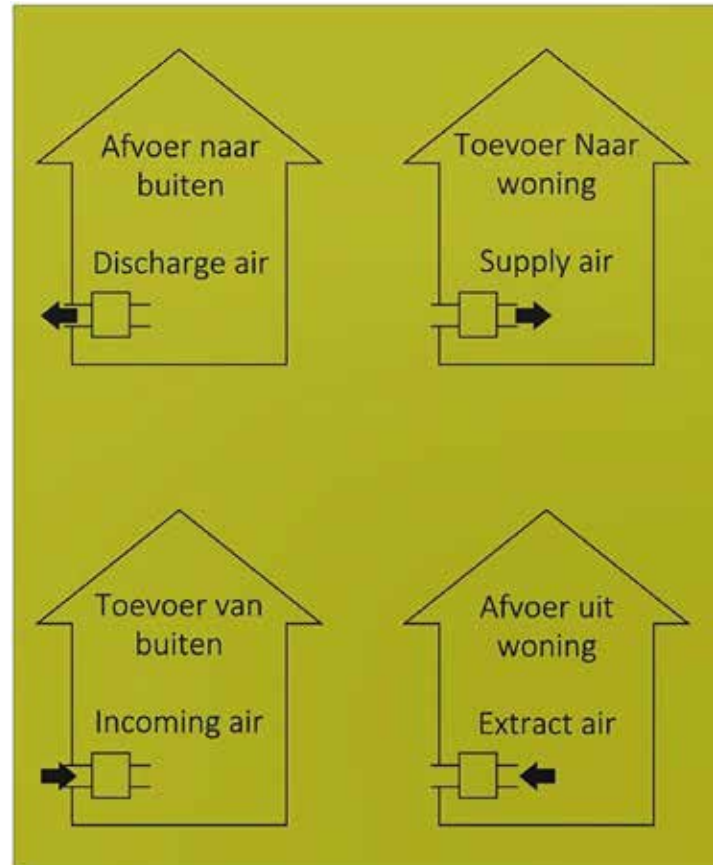
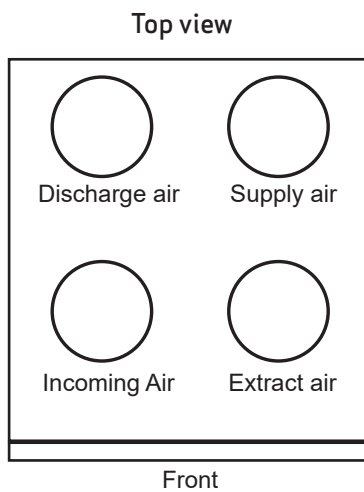

Ducting System

To build an airtight and durable ducting system, we recommend that the ducting system be made from spirally flanged pipes using fittings with a rubber ring seal.

To keep the noise level from the unit satisfactorily low, always mount silencers on the supply air and extract air ducting systems between the unit and the first air intake and extract valves.

To prevent the air intake and extract valves from generating any noise, it is recommended that air speeds in the ducting be kept sufficiently low.

Insulation of Ducts in Cold Spaces

To take advantage of the high heat recovery potential of the unit (efficiency), it is necessary to insulate the ducts properly.

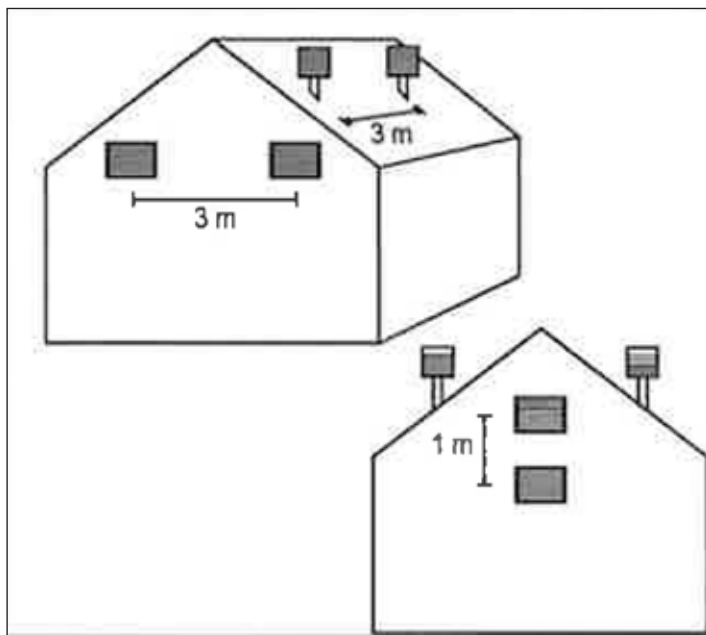

Supply Air and Extract Air Ducts

To minimise heat loss from the ducting system in cold lofts, insulate the supply air and extract air ducts with a minimum of 100 mm insulation. If insulation form alternative (A) is used, it is recommended that it takes the form of two layers of 50 mm lamella mats with paper or foil externally and staggered joints between the two layers. If the ducts are laid on the rafter foot, alternative B may be used. The insulation must always be tightly packed around the ducts.

Fresh Air and Discharge Air Ducts

It is recommended that fresh air and discharge air ducts be insulated with a minimum of 50 mm insulation followed by aluminium foil. The fresh air duct is insulated to prevent warm air in the loft from heating up the fresh air in the summer.

To avoid condensation damage, make sure that the place where the discharge air duct passes through the roof or the gable end is sealed well.

When placing outdoor air and exhaust air hoods/gratings, care must be taken not to short-circuit the two airflows, thus causing exhaust air to avoid being sucked back in. It is recommended that gratings be placed on the north or east side of the house for optimal comfort in homes/ apartments. Minimum distance: 3 or 1 meter depending on orientation of the grates. Ensure that the fresh air intake is not affected by sun heating of roof and fresh air intake.. Please refer to drawing

Refer to your local distributor for guidance on national insulation directives.

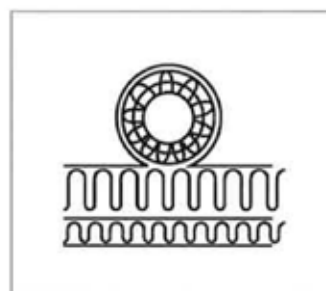

Duct insulation, alt. A

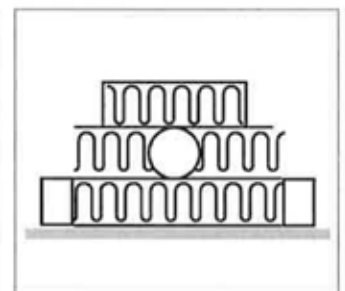

Duct insulation, alt. B

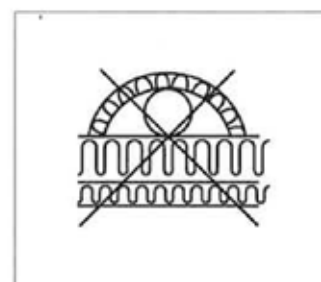

Incorrect duct insulation

Insulation of Ducts in Heated Spaces

Genvex recommends, as follows:

Supply Air and Extract Air Ducts

If the loft is warm, insulate the supply air and extract air ducts with 50 mm of insulation followed by aluminium foil.

Supply air and extract air ducts passing through heated spaces in dwellings do not require insulation unless cooling, a bypass or an earth heat exchanger is used. In this case, the supply air duct must be insulated.

Fresh Air and Discharge Air Ducts

Insulate the fresh air and discharge air ducts in warm lofts and heated rooms in dwellings with a minimum of 50 mm insulation. Also cover the insulation externally with plastic film or aluminium foil to avoid formation of condensate in the insulation. Refer to your local distributor for guidance on national insulation directives.

We recommend 100 mm of insulation on the fresh air duct when an earth heat exchanger or precooling/brine coil is used.

Water Connection

The following connections are located at the bottom of the hotwater cylinder:

- 3/4" RG branch pipe for: Cold water/Recirculation/Hot water

Optional Connection of Heating Coil

The tank is fitted with a 0,75-m² heating coil with 3/4" RG connections.

The heat exchanger is enamelled externally.

The tank connections are 3/4" RG. A sensor controlling external heat sources such as solar heating panels, an oil burner or a wood burning boiler can also be mounted in the free sensor pocket at the bottom of the tank. The maximum diameter of the sensor is 6 mm.

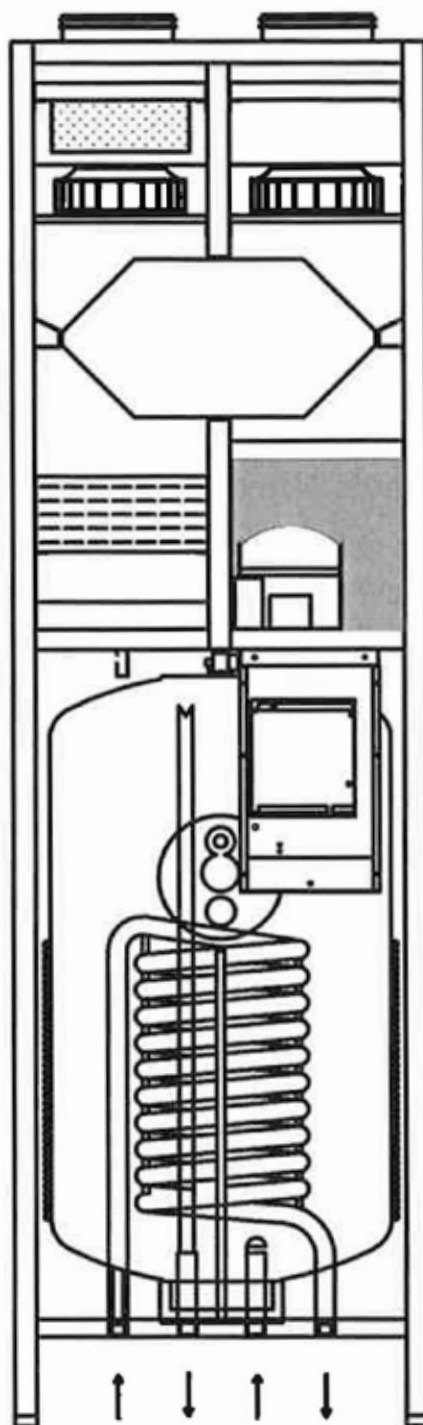
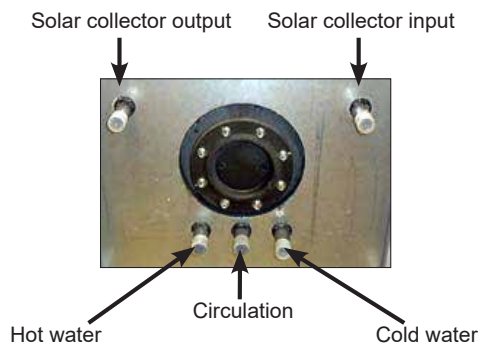

Electric Water Heater/Sensor/Anode/Thermostat

These are placed on the bottom front of the unit, behind the front cover and underneath a steel plate.

The electric backup immersion heater will ensure that additional heating capacity can be applied if required. This could be beneficial for example if the full capacity of the Combi unit is dedicated to room heating or cooling. The activation of the electrical backup heater in this case will ensure that domestic hotwater can be produced simultaneously.

The safety thermostat will trip at 80 °C and ensure that the electrical water heater will not activate until the safety thermostat has been reset. Resetting the thermostat is done by pressing the small button on the thermostat.

The anode protects the domestic hotwater cylinder against corrosion and should be checked every 2 years to ensure that sufficient protection is present.

To check if the anode protection is intact, remove the ground connection of the domestic hotwater cylinder and use a multimeter to check if the anode current is greater than 0,3 mA by measuring directly on the anode and the ground connector.

Between the anode and electrical immersion heater, a sensor pocket for the temperature sensor switching the electrical heater on and off is located. Do not remove the temperature sensor in the sensor pocket as this will prevent the Combi controller from shutting down the electrical heater if the temperature in the cylinder is sufficient.



Electrical water heater

Safety thermostat

Temperature sensor T7

Anode

Electrical Installation

The connection to the mains must be performed by a certified electrician. (See the enclosed electrical diagram).

On the top of the unit it is possible to connect an internet connection for the connectivity features of the Combi. Furthermore a Optima Touch display can be connected. If the pre-installed 1.8 metre cable for the Optima Touch display is not long enough, it is possible to replace this with a 4-core 0.25 mm² twisted pair cable with a length of up to 50 metres.



The unit may only be operated with a full tank.



The unit must always be disconnected from the electrical power source before the front hatch is dismantled. Once the unit has been disconnected from the mains, wait until the fan has come to a standstill before opening the hatch.



Do not drill any holes in the unit.

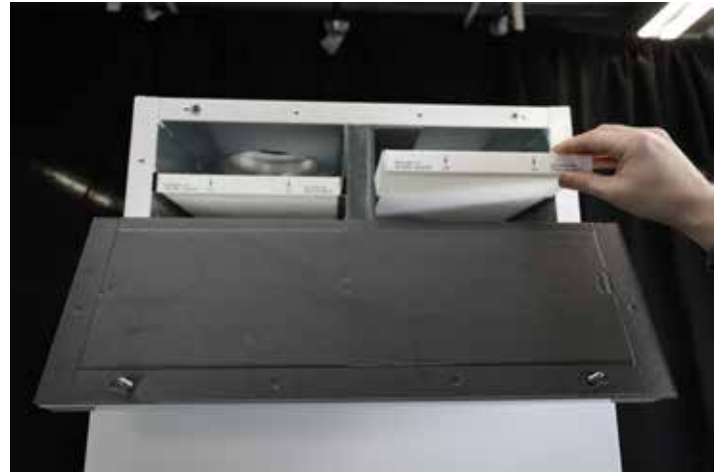

Filters can be replaced by removing the two top screws from the filterlid. the filterlid can then be opened to access the filters inside the Combi unit.

System Inspection and Fine-Tuning

To ensure optimal operation of the system, fine-tune it first using professional air-measuring equipment.

Check the following points, while keeping in mind that the system can be put into operation before the fine-tuning.

1. Check that the system has been mounted correctly and that all ducting has been insulated in accordance with the instructions.
2. Check that the various hatches can be opened so that it is possible to service and maintain the unit.
3. Check that the filters are clean (they can be dirty after installation), and replace if necessary before fine-tuning.
4. Check that the condensation drainage is mounted correctly with a water trap and that this is protected against frost.
5. Pour 1 l of water into each of the condensate trays and check that the condensate flows away efficiently into the drain. Ensure that both of the watertraps contain 100 mm watercolumn.

Default setting if the system is started up prior to fine-tuning:

- Adjust all supply air valves so that the valve which is closest to the unit is open at 3 turns from the closed position, while the one furthest away is open at 8 turns from the closed position.
- Then open the valves in between at 4 to 7 turns depending on how close they are to the unit.

Optimal Fine-Tuning of the System

Use air-measuring equipment. Check that all 5 items in the section above have been carried out before performing the fine-tuning. Then put the system into operation.

Set up the system for basic ventilation, i.e. speed 2. To reduce energy consumption as much as possible, first adjust the overall atmospheric volume to the desired level by changing the speed settings in the Service Menu.

Then fine-tune the supply air and extract air valves with the air-measuring equipment. Remember to lock the valves when performing the fine-tuning and to turn the conducting plate on the supply air valves so that air blows in the right direction.

Finally, recheck and fine-tune the overall atmospheric volume by adjusting the speeds for Step 2 in the Service Menu.

Then adjust Step 1 and Step 3 to an appropriate interval in relation to Step 2.

Please be aware that the airflow required during heatpump operation can differ from when only ventilation is required.

Requirements to the Hot Water Circuit

The following materials can be used for the hot water installation:

- Copper
- Stainless steel
- Brass
- Synthetic materials

This naturally depends on the materials that have already been used in the water circuit (of the dwelling). Incorrect material combinations may result in corrosion damage.



This requires particular attention when galvanised components and components containing aluminium are used.

Initial Operation of the Water Circuit

- Fill the tank via the connector spigot and then air it out by leaving one of the uppermost hot water spigots open until no more air comes out.
- Recheck the entire water circuit for leaks.
- Connect the unit to the mains.

Inspect all connections of the water circuit for leaks after start-up.

Cooling Circuit

The unit is delivered as a preassembled unit. No work needs to be done on the cooling circuit. The control unit will automatically assume control of all functions and start up the compressor, fan, etc. in order to maintain the set water temperature.

Heat Exchanger Operation

Heating Boiler

Heat exchanger operation is used if you, for example, only want to heat water via an external heating boiler in the winter (an oil burner, for example). Set the Combi unit to the lowest acceptable water temperature, and it will then function as an emergency back-up. Afterwards, it will be the thermostat of the oil burner that will determine the heating of the water.

This mode of operation requires the installation of an extra sensor in the tank for controlling the boiler. The maximum water temperature must be limited to 65 °C. The temperature can be exceeded for short periods of time, for example, in connection with disinfection.

If the boiler is to function as an extra heat source for the unit, the temperature of the thermostat of the boiler should be set about 5 °C lower than the thermostat of the unit itself. This will ensure that the boiler is only operating when water consumption cannot be covered by the unit.

When the unit is put into operation, it is necessary to ensure that sensor values are set as desired.

Wood burner or solar collector

This optional operational connection can be used if the function of the unit is to be supported by a wood burner or a solar collector installation.

Sensor T9 (see the diagram on the next page) measures the temperature in the wood burner or the solar collector. If the temperature is higher than the water temperature in the tank, it is possible for the control unit to activate a circulation pump which will circulate water through the coil in the tank, thereby heating the water. Hysteresis can be set up at 0-5 °C. Maximum temperature is 60 °C. Above this temperature, the control unit will disengage the pump in order to protect the tank.

Do not set the water temperature higher than necessary. The lower the temperature, the higher the efficiency of the unit. Only use high temperatures when necessary

Fan Operation Tips

Do not ventilate more than necessary. Over-ventilation often results in very low humidity inside the dwelling, which causes discomfort. In addition, it is a waste of energy to over-ventilate. However, always make sure that there is compliance with the required minimum atmospheric volume.

Rechecking

After installation, we recommend that you check that all connections are water and airtight and that condensed water will flow off without a hindrance.

Energy-Saving Tips

ELECTRICAL DIAGRAMS

Optima 314

Sensor T1 Supply air



Sensor T2 Extract air

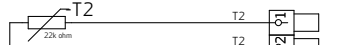

Sensor T3 Outdoor air

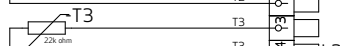

Sensor T4 Exhaust air

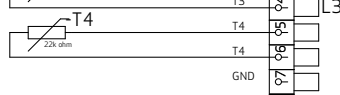

Potential free input for optional:
Humidistat, Extractor hood

External stop

Sensor T9 solar collector / option



Sensor T5 Before evaporator

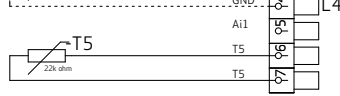

Sensor T6 Evaporator



Sensor T7 Hotwater top cylinder

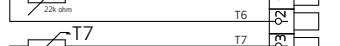

Sensor T8 Hotwater bottom cylinder

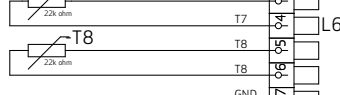

Solar cell input 0-10V

Humidity sensor

Pressure transmitter 0-10 Bar
(Low pressure)

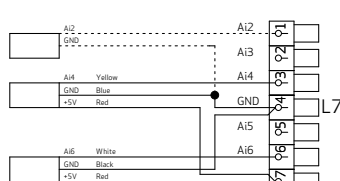

SG Ready input

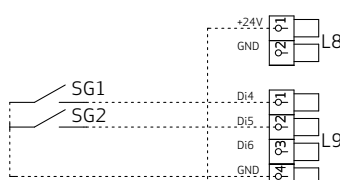

Supply air fan 0-10V + Tacho

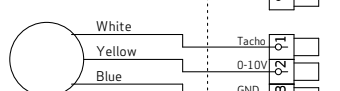

Extract air fan 0-10V + Tacho

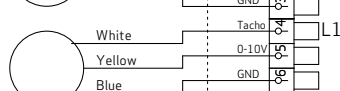

Modbus - ES1048B

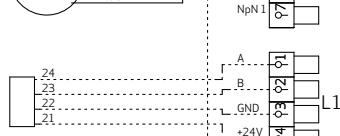

Modulating Preheating

Modulating Reheating

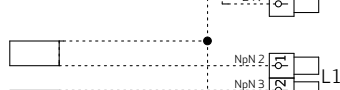

Optima 314 Touch

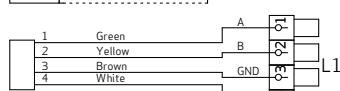

Modbus - ES1095

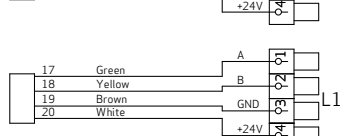

Modbus slave / CTS / CO2 Sensor

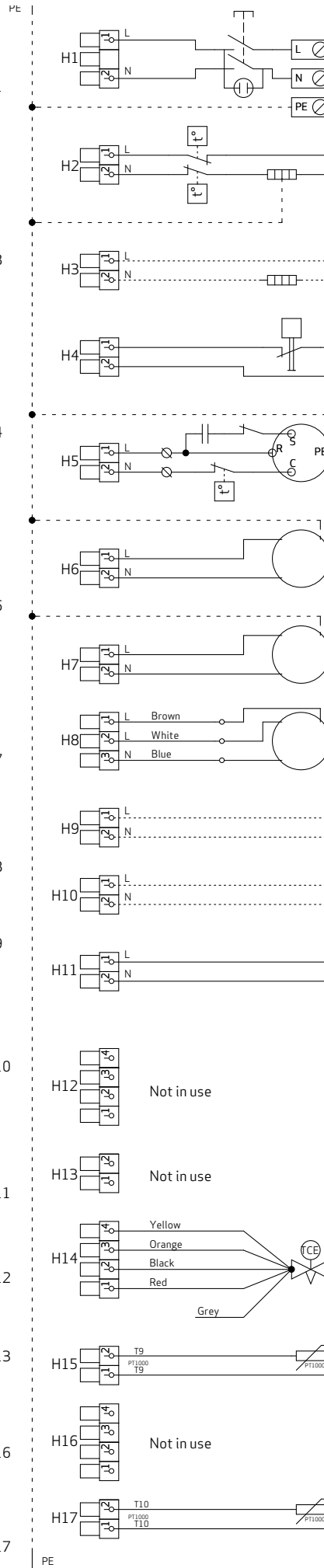
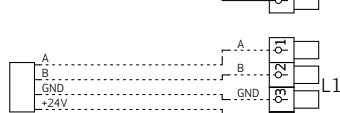

Mains connection
1x230VAC, L-N-PE
Max: 13A

DHW heater 1000W

Electric Pre/re-heater
Max 1200W

High pressure switch

Compressor 230V

Supply air fan 230V

Extract air fan 230V

Bypass
Belimo
CM230-F-R
ON/OFF

Aux. relay H9
1x230V 50Hz
ONLY control current

Aux. relay H10
1x230V 50Hz
ONLY control current

Supply for ES1095

Not in use

Not in use

Electronic Expansion Valve

E-valve sensor T10 @ Condenser

Not in use

E-valve sensor T11 @ Evaporator

- L1 + L2:
Sensor T1
- L3:
Sensor T2, T3, T4
- L4 + L5:
Sensor T5, T9
Hygrostat
External stop
- L6:
Sensor T6, T7, T8
- L7:
Humidity sensor
Solar cell 0-10V
Pressure transmitter
- L8:
+24V terminal
- L9:
Smart Gridt
- L10:
Supply air fan 0-10V + Tacho
Exhaust air fan 0-10V + Tacho
- L11:
Modbus - Fire box ES1048B
Modbus - District heating ES1048B
- L12:
Modulating Preheating
Modulating Reheat
- L13:
Optima 314 Touch
- L14:
Modbus USB
- L15:
DipSwich
- L16:
Combi Blueline relay box ES1095
- L17:
Modbus Slave / CTS / CO2 sensor

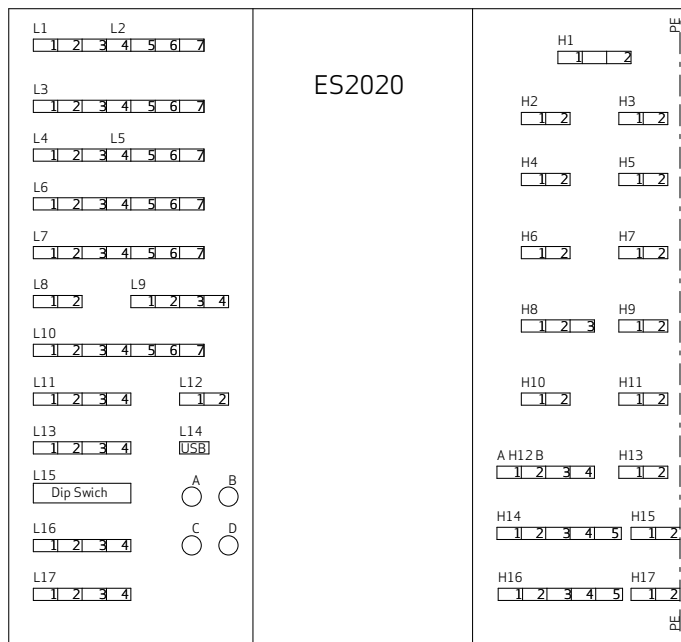

- H1:
Mains connection 230V L-N-PE Max 13A
- H2:
Electric immersion heater 230V
- H3:
On/Off Electric Pre/reheater 230V
- H4:
High pressure switch
- H5:
Compressor 230V
- H6:
Supply air fan 230V
- H7:
Extract air fan 230V
- H8:
Bypass 2x230V
- H9:
AUX relay H9 230V
- H10:
AUX relay H10 230V
- H11:
Combi Blueline relay box ES1095 230V
- H12:
Not in use
- H13:
Not in use
- H14:
Electronic expansion valve
- H15:
Sensor T10
- H16:
Not in use
- H17:
Sensor T11

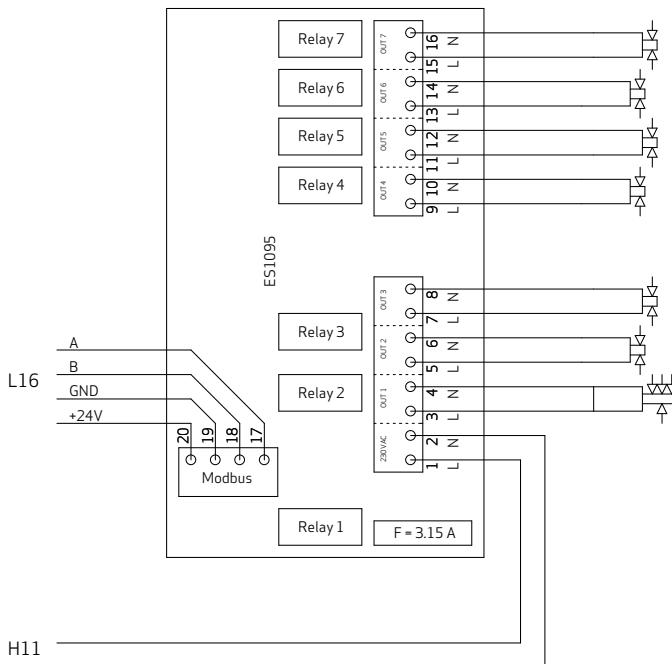

- MA7 - Soleniod valve Condensor out - Room heating mode
- MA6 - Equalization valve - Water heating mode
- MA5 - Equalization valve - Room heating mode
- MA4 - Soleniod valve Defrost
- MA3 - Soleniod valve - Water heating mode
- MA2 - Soleniod valve Condensor in - Room heating mode
- MA1 - 4-way valve - Cooling mode

FLOW DIAGRAM

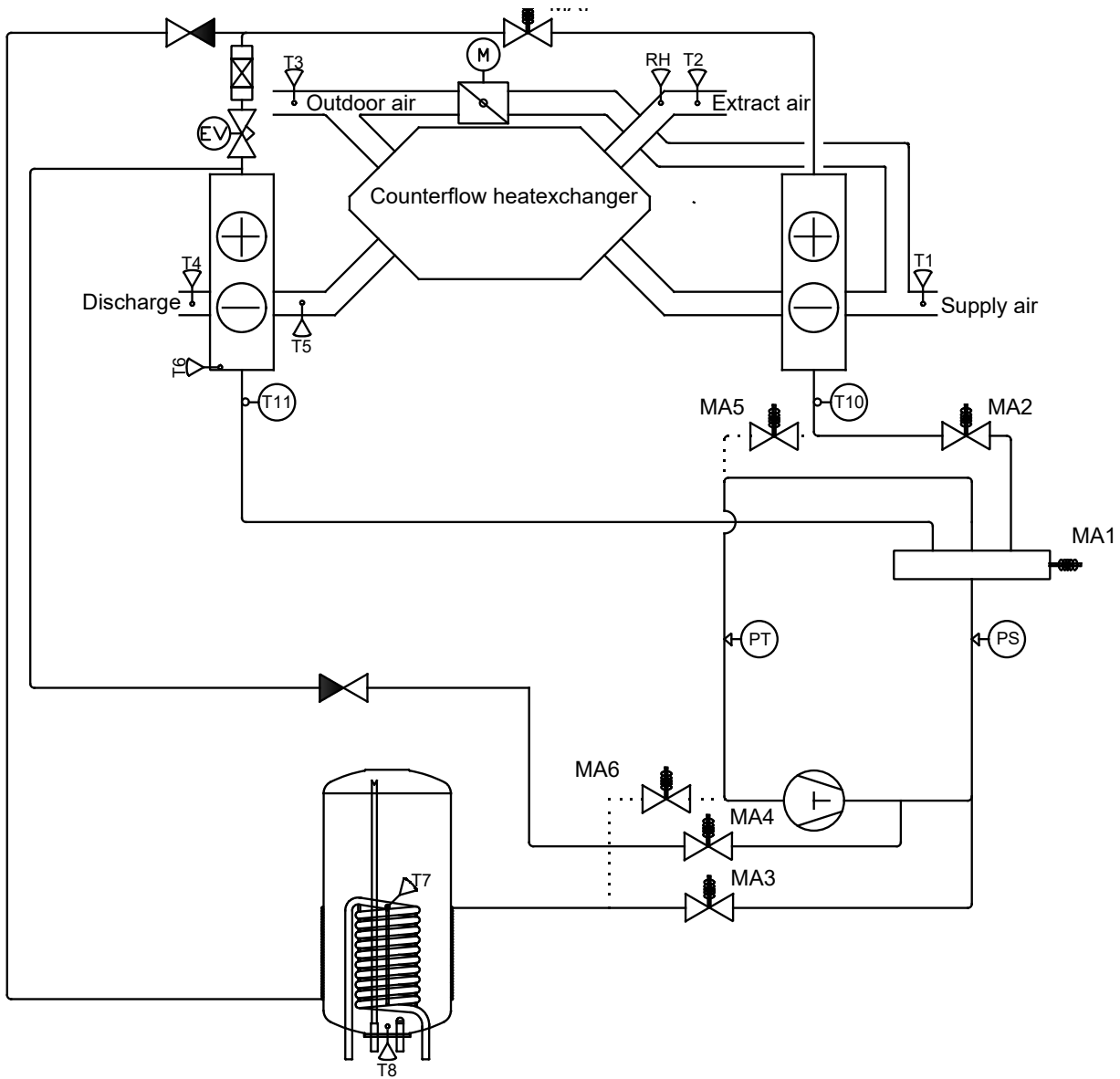

Sensors

- T1: Supply air
- T2: Extract
- T3: Fresh Air
- T4: Discharge air
- T5: Before cooling coil
- T6: Cooling coil
- T7: Tank, top
- T8: Tank, bottom
- T9: Solar collector (optional)
- RH: Humidity sensor
- T10: Superheat temp sensor (cooling mode)
- T11: Superheat temp sensor (heating mode)

HYDRAULIC CONNECTIONS

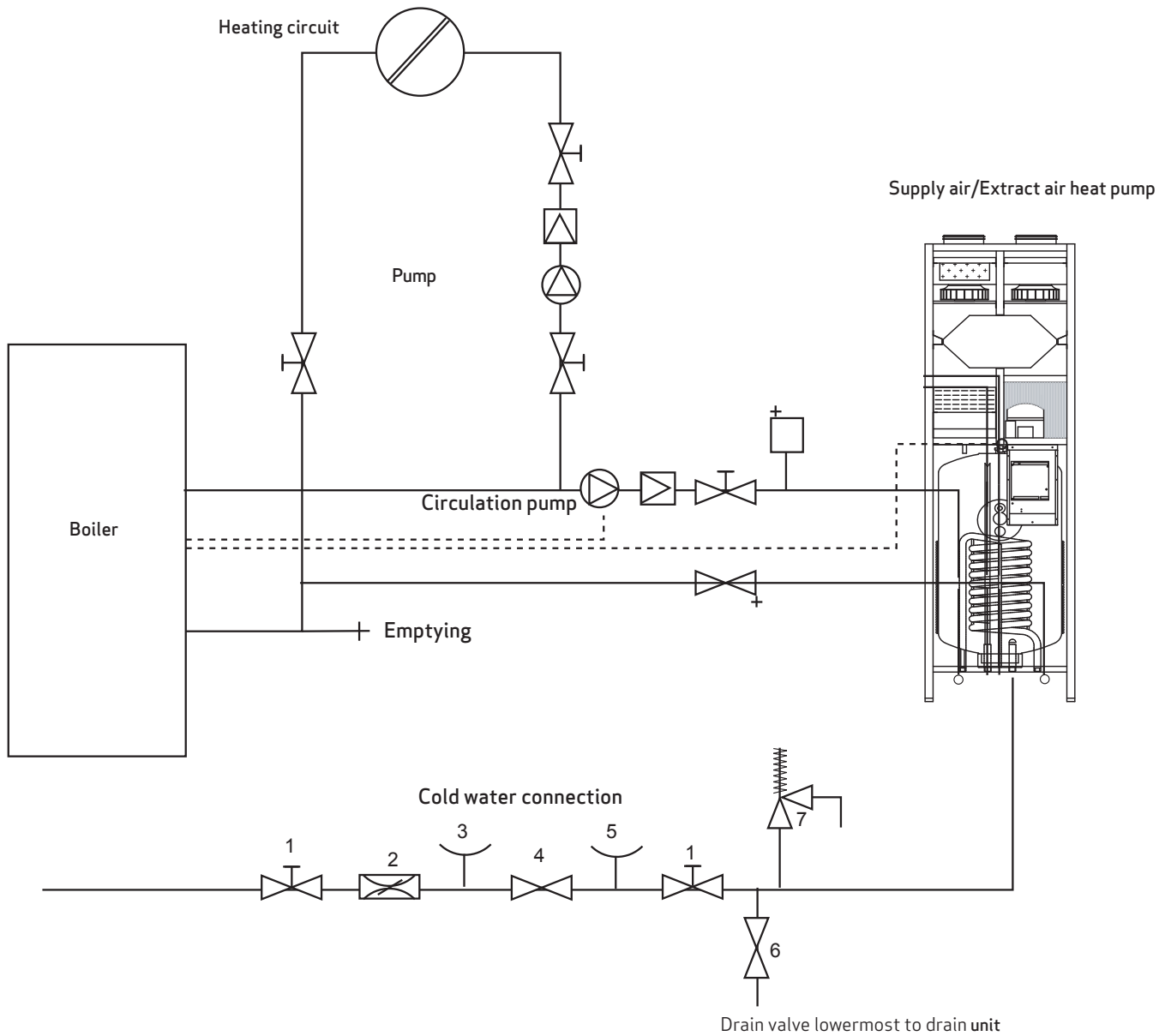

- 1: Check valve
- 2: Pressure reducing valve
- 3: Test valve
- 4: Non-return valve
- 5: Pressure gauge connection piece
- 6: Drain valve
- 7: 10.0 bar safety valve



If you connect your heat pump to a boiler or a solid fuel boiler, make sure that the maximum temperature of the domestic hot water does not exceed 65 °C and that the pressure in the Solar coil heat exchanger does not exceed 3 bar!

MODES OF OPERATION

Waterheating

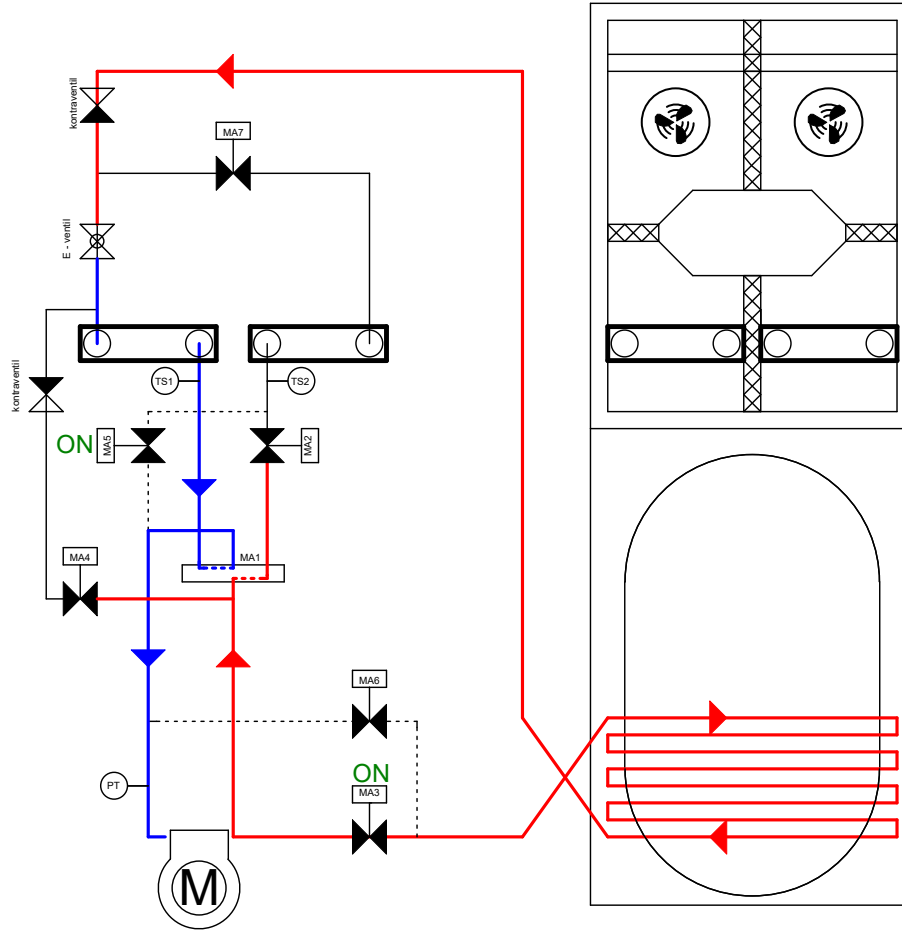

Airheating

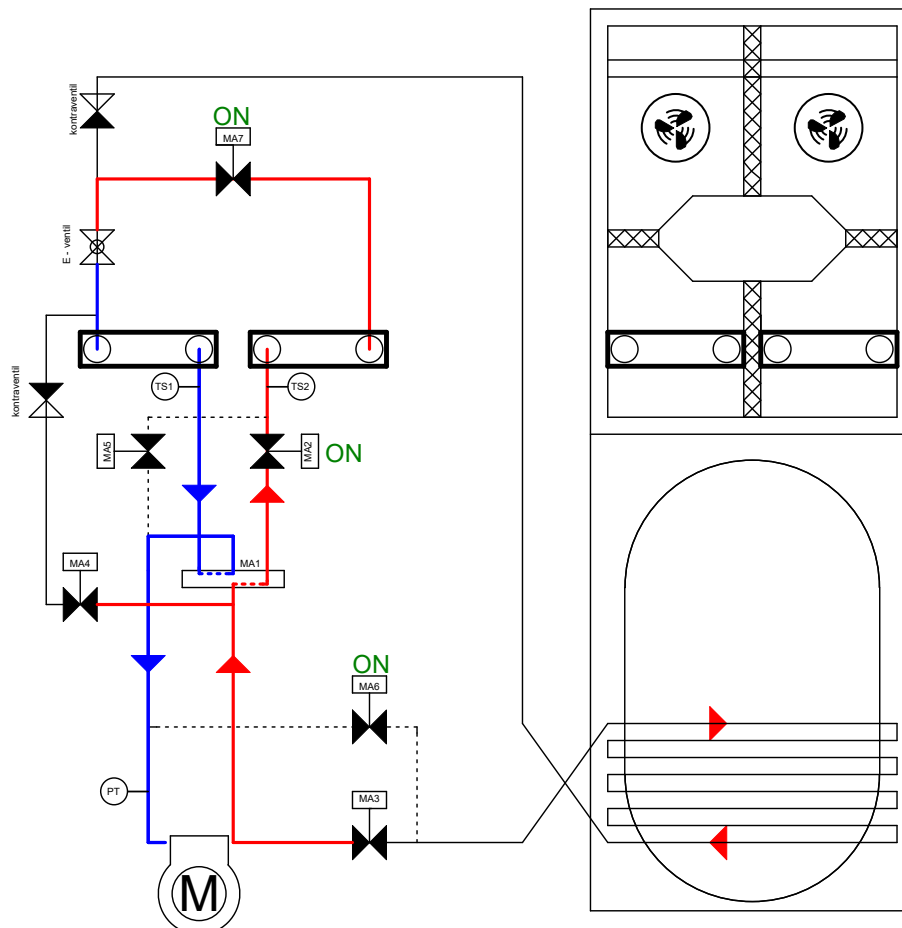

Active air cooling

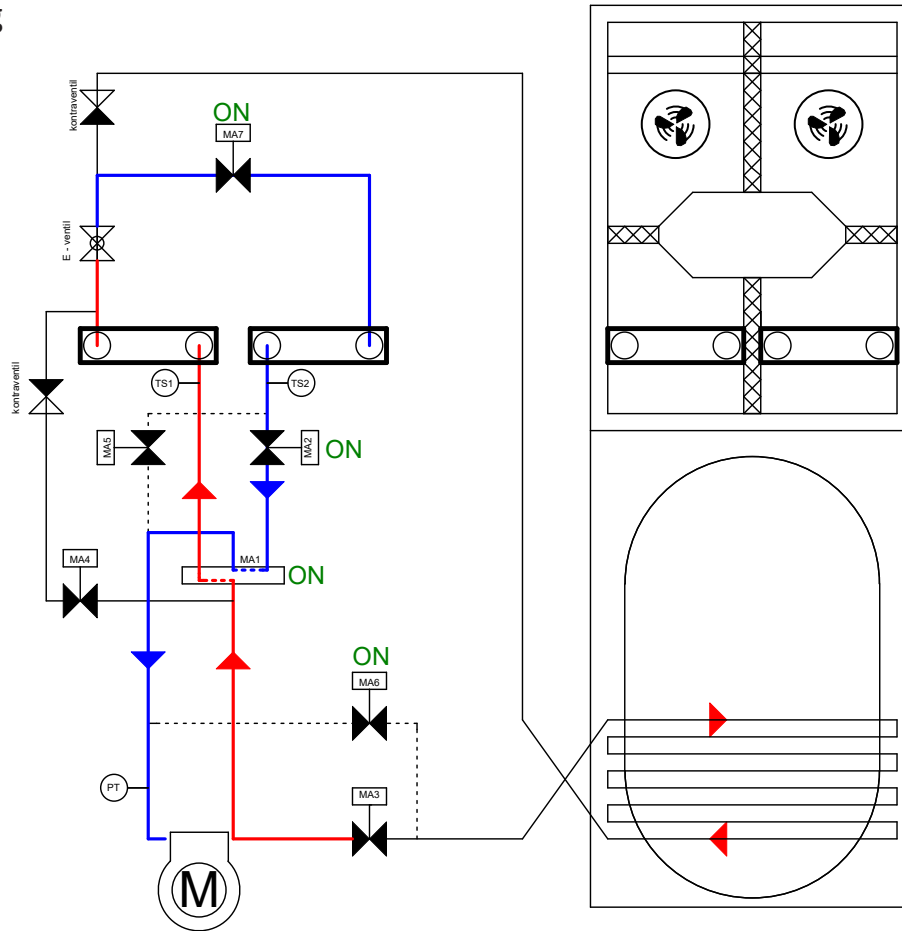

Defrosting evaporator

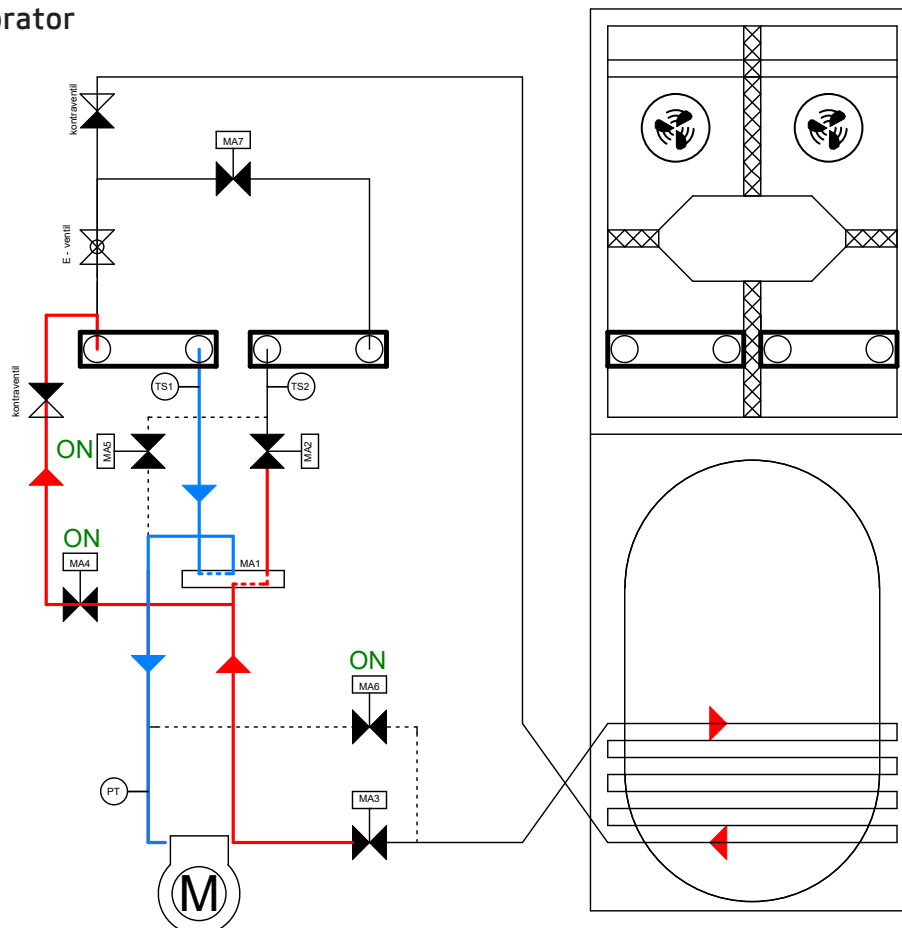

SPARE PARTS

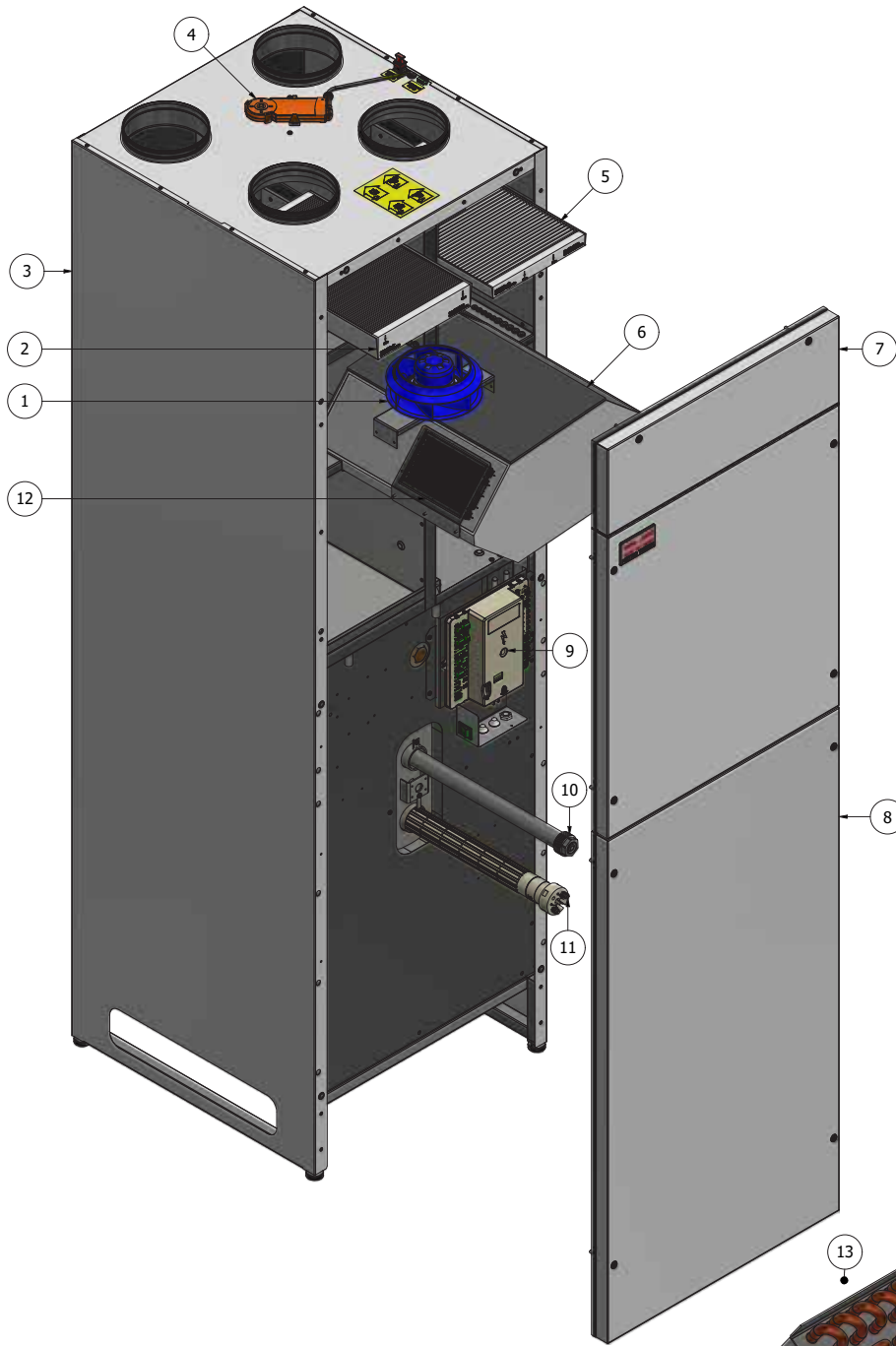

Pos.	Stock nr.	Part
1	070056	Fan 90W
2	060701	Filter - ePM1 / F7 - 50 mm.
3	069779	Sideplate +R, RAL 9016
4	060537	Bypass motor
5	060776	Filter - Coarse / G4 - 25 mm.
6	041162	Heat exchanger - GS 25 X 420 ALU
7	043062	Top Front door
8	042897	Bottom Front door
9	074074	Opima 314 controller
10	045776	Anode
11	045724	Electrical heating element 1000 watt
12	069910	Pre heater
13	061052	Complete cooling assembly
14	074007	Temperatursensor, AKS 11
15	074000	Coil - SAGINOMIYA
16	074001	Valve - SAGINOMIYA
17	074075	Relay box
18	061159	Valve - Pressure compensation
19	061187	Coil - Pressure compensation
20	061168	Valve 1/4 - Defrost
21	061167	Valve 3/8 - Water/Air
22	042373	Coil - Water/Air
23	061149	High pressure switch
24	061022	Compressor
25	074004	Check vaalve
26	074005	Electric exp. valve
27	074010	Coil for Elec. Exp. Valve
28	074003	Pressure transmitter
29	074006	Bi-flow dry filter
30	061220	4-way valve with coil
31	074007	Temp. sensor heatpump
32	045132	Temp. Sensor air 2200 mm.
33	022430	Humidity sensor 1300 mm.
34	045116	Temp sensor evaporater

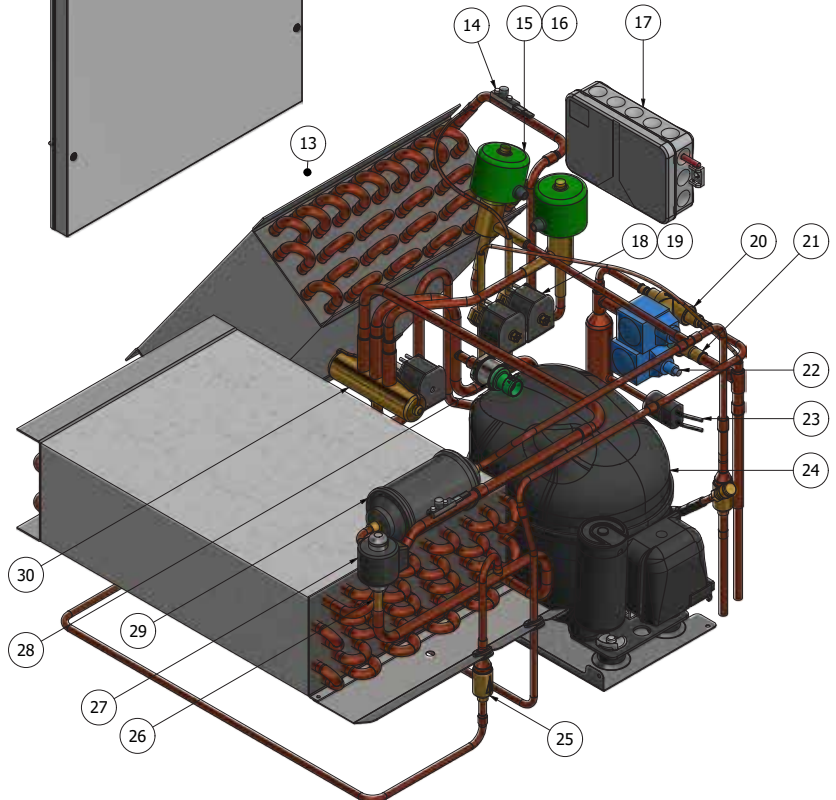

Please note:

Component configurations might vary depending on the current model. Please state the serial number of the unit when ordering spare parts.

DECLARATION OF CONFORMITY

The declaration of conformity can be found on our website: www.genvex.com

THE AIR WE BREATHE

All
Genvex
systems are
rated with
energy label

A

Genvex develops ventilation units that use as little energy as possible, whilst still being as efficient as possible. This is good for the environment – and will also save you money. Our units comply with all applicable standards and are easy to use, install and maintain. Last – but not least – all Genvex units have compact dimensions that makes them easy to install seamlessly in all types of homes – large or small.

Genvex is a part of the Swedish NIBE Group, which has specialised in providing environment-friendly energy solutions throughout the last 70 years. The NIBE group consists of more than 140 companies all over Europe.



Genvex – the original Danish ventilation system

Genvex is a true Danish original. We started producing ventilation systems in 1978 and are still the front runners when it comes to development and production of the most innovative and durable ventilation systems on the market.

Our units are installed in thousands of homes, providing clean, fresh air free from pollen, dust and harmful particles. They help lots of families with maintaining a healthy and comfortable indoor climate and prolong the longevity of the house itself. With very high heat recovery rates, a Genvex system lets you recover and reuse up to 95 % of the heat inside your home. As a result, our units provide a strong contribution to energy savings in both in family homes and in society as a whole.

Please visit www.genvex.com to see a list of our distributors